

Overview

Temco Controls manufactures temperature sensors for the air conditioning industry.

This document shows the enclosures, and temperature vs resistance curves for the standard sensors.

General

The sensors employ precision interchangeable thermistors and RTD which are compatible with all the major building automation systems.

- designed specifically for temperature sensing for Air Conditioning and light industrial control applications.
- precision interchangeability eliminates the necessity for individual circuit calibration.
- data sheets for the standard items appear on the web at www.temcocontrols.com.
- Temco is able to produce custom sensors in small volume at standard sensor pricing.

Temco sensors is used to measure the supply and return air temperature in HVAC systems. There are several sensor element ranges to choose from, which guarantee compatibility with all popular DDC systems. The sensor elements are precision thermistors or platinum RTDs. Field calibration is not generally required. The probe is epoxy sealed to prevent moisture from migrating into the probe. The standard probe length is 12 inch. Custom probe lengths, wire types and sensor elements are available for large OEM projects. Ask about our plastics & metal manufacturing capabilities for custom housings as well.

Part # Suffix	Sensor	Typical User
2	100 ohm Platinum 3-wire	Honeywell
5	1,801 ohm Thermistor	t.a.c. / CSI
6	3,000 ohm Thermistor	Alerton
7	10,000 ohm Thermistor 'Type2'	Andover, AAM, Teletrol, Invensys(Siebe), Multinet, Delta, Carrier, KMC, Temco
9	100,000 ohm Thermistor	Siemens(Landis & Staefa)
11	LM334 IC sensor	t.a.c. / CSI
12	1000 ohm Platinum	Invensys(siebe), Honeywell, Johnson Controls, Siemens (Landis & Staefa)
13	1000 ohm Nickel	Johnson Controls
20	20,000 ohm Thermistor	Honeywell
21	LM335 IC Sensor	Solidyne, IECC
24	10,000 ohm Therm, 'Type 3'	Trane, Automated Logic, Temco, t.a.c., CSI, Solidyne, Alerton

Specifications:

Sensor Property	Specification
Thermistor Accuracy	+/- 0.2°C
Platinum RTD Accuracy	+/- 0.4°C
Thermistor Range	-70°C to 150°C
Platinum RTD Range	-70°C to 200°C
Probe Material	Stainless Steel
Cable Properties	FT4, 80°C, 600V

Temperature Curves:

Thermister Type, Ohms / Part Number Suffix						
Part # -> DegC	3K -6	10K Type2 -7	10K Type3 -24	20K -20	100K -9	1K RTD -12
-40	100,701	335,671	239,700	814,000	4,067,212	843
-35	72,658	242,195	187,500	578,600	2,890,843	863
-30	53,005	176,683	135,300	415,600	2,077,394	882
-25	39,073	130,243	107,105	301,000	1,508,530	902
-20	29,092	96,974	78,910	220,600	1,106,485	922
-15	21,868	72,895	63,225	163,600	819,378	941
-10	16,589	55,298	47,540	122,380	612,366	961
-5	12,694	42,314	38,515	92,300	461,683	980
0	9,795	32,650	29,490	70,200	351,017	1,000
5	7,618	25,395	23,460	53,800	269,041	1,020
10	5,971	19,903	18,790	41,560	207,807	1,039
15	4,714	15,714	15,130	32,340	161,702	1,059
20	3,748	12,493	12,260	25,340	126,729	1,078
25	3,000	10,000	10,000	20,000	100,000	1,105
30	2,416	8,056	8,194	15,884	79,428	1,117
35	1,959	6,530	6,752	12,696	63,489	1,136
40	1,597	5,324	5,592	10,210	51,058	1,155
45	1,310	4,366	4,655	8,258	41,301	1,175
50	1,080	3,601	3,893	6,718	33,598	1,194
55	896	2,985	3,327	5,494	27,479	1,205
60	746	2,487	2,760	4,518	22,593	1,232
65	625	2,082	2,375	3,734	18,669	1,244
70	526	1,751	1,990	3,100	15,502	1270.7
75	444	1,480	1,724	2,586	12,932	1,290
80	377	1,256	1,458	2,186	10,837	1308.9
85	321	1,070	1,271	1,824	9,121	1,328
90	275	916	1,084	1,542	7,709	1,347
95	236	787	950	1,308	6,542	1,366
100	204	679	817	1,114	5,574	1385
105	176	587	720	953	4,767	1,404
110	153	510	624	818	4,093	1422.9
115	133	445	553	705	3,525	1,442
120	117	389	481	609	3,046	1,460

RTS-Raw 10K NTC Thermistor

Specifications:

Rated Resistance: $R_{25}=10.00k\Omega \pm 1\%$

B-Value: $B_{25/50}=3950\Omega \pm 1\%$

Operating Temperature: $-30 \sim +80^{\circ}\text{C}$



Dimensions (mm):

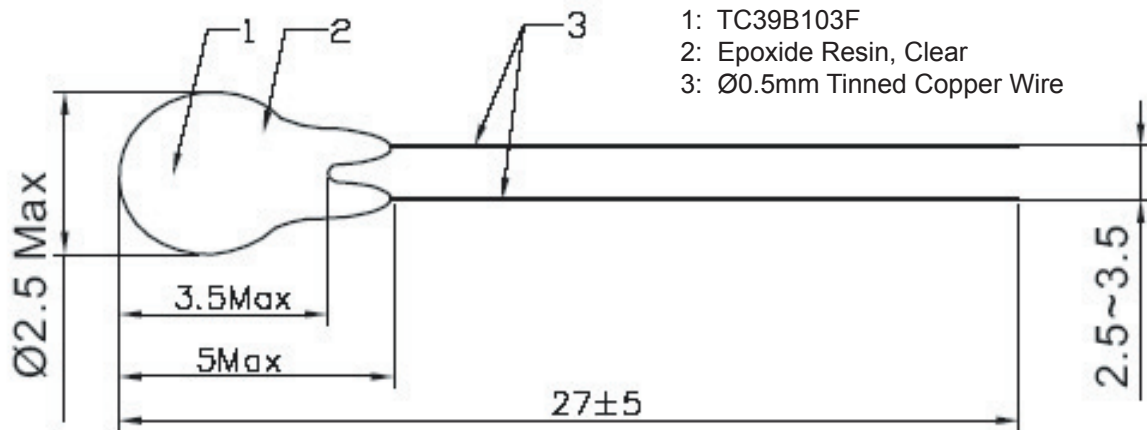

RTS-Bead-4: Thermistor bead, 4"(10cm) lead, 10mm wire trimmed and tinned, 0.2DegC accuracy

Specifications:

Zero Power Resistance: $R_{25}=10.00k\Omega \pm 1\%$

B-Value: $B_{25/50}=3950K \pm 1\%$

Operating Temperature Range: $-30 \sim +80^{\circ}\text{C}$

Insulated Resistance: 500VDC in water, $>100M \Omega$

Breakdown Voltage: 1500VAC in water, 1 minute.

No flash over (Leak Current: 1mA Max).



Dimensions (mm):

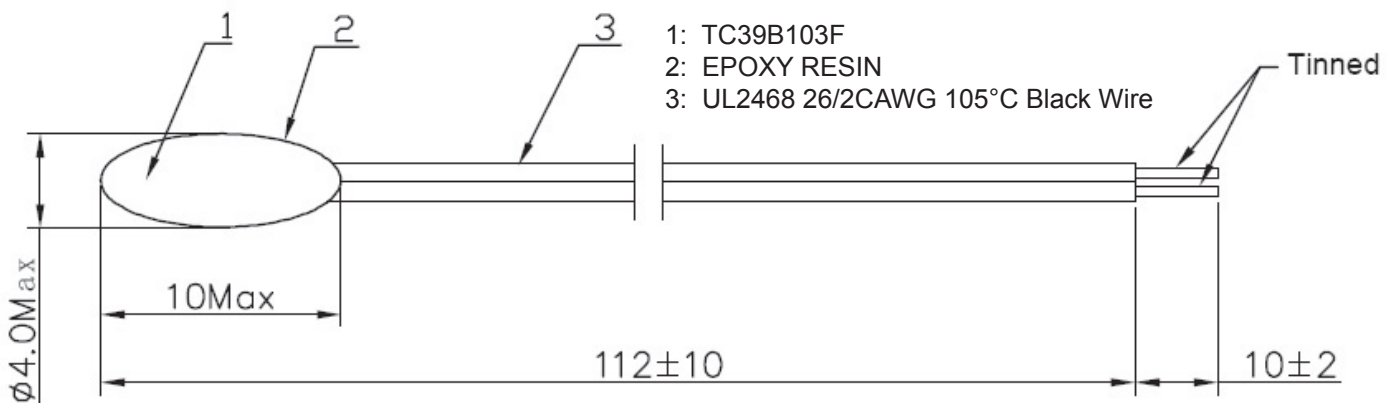

Temperature Sensors

TS-10K-0.6SSP-7 Temperature Sensor: 0.6" SS probe temp sensor, 10K thermistor, type 2

Specifications:

- Nominal Resistance: $R_{25}=10.00k\Omega\pm 1\%$
- B Value: $B_{25/50}=3950K\pm 1\%$
- Operating Temperature Range: $-30 \sim +80^{\circ}C$
- Insulated Resistance: 500VDC in water, $>100M\Omega$
- Breakdown Voltage: 1500VAC, 1min.



Dimensions (mm):

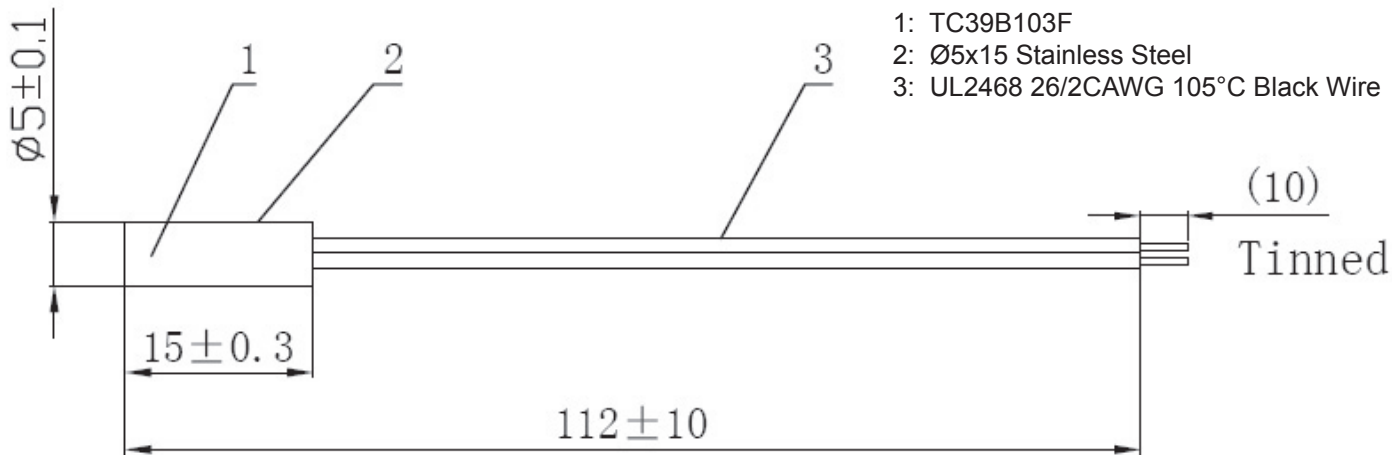

OAT3000 Temperature Sensor

Specifications:

- Nominal Resistance: $R_{25}=10.00k\Omega\pm 1\%$
- B Value: $B_{25/50}=3950K\pm 1\%$
- Operating Temperature Range: $0 \sim +50^{\circ}C$
- Insulated Resistance: 500VDC in water, $>100M\Omega$
- Breakdown Voltage: 1500VAC, 1min.



Dimensions (mm):

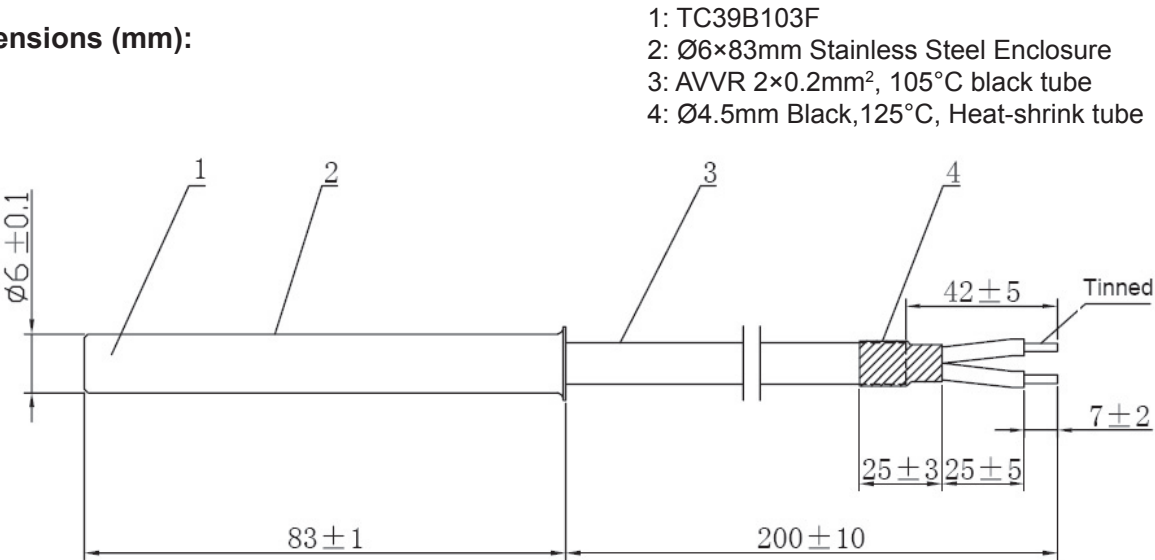

Duct Temperature Sensor

Plastic Water Resistant Box:



Plastic Box for 1/2" EMT Connection:



Electrical Box:

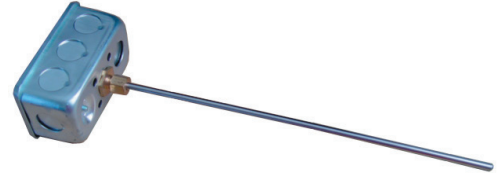

Dimensions(mm):

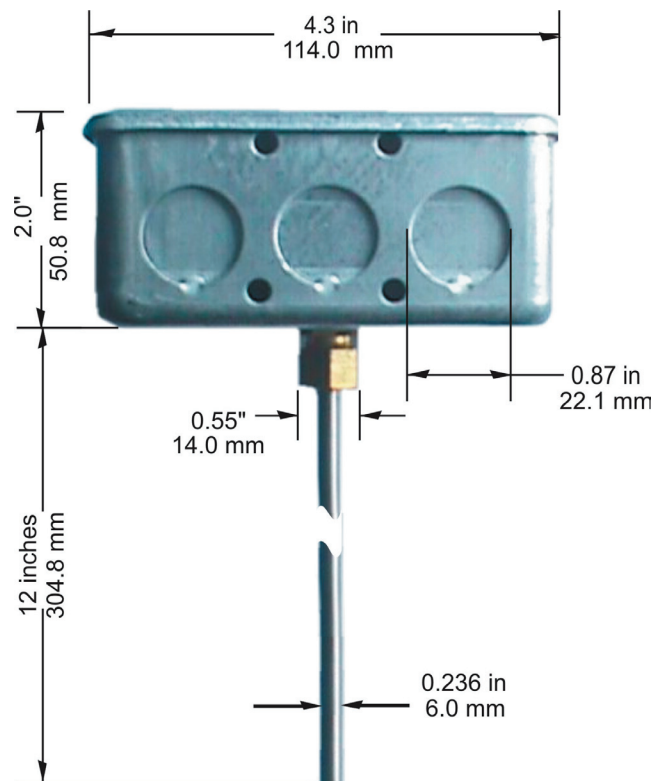
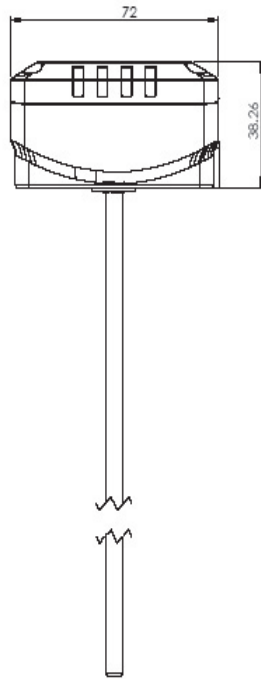
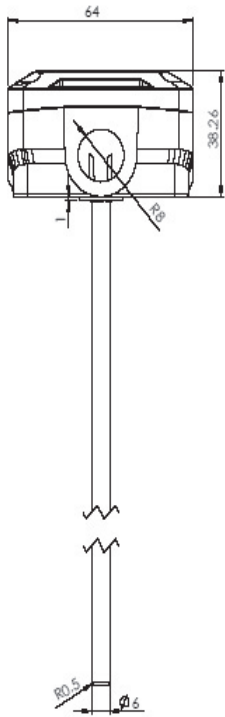

Ordering Information:

DTS - PE - 12 - 7

Code	Description
DTS	Duct Temperature Sensor

Code	Probe Size
8	8"
12	12"

Code	Temperature Curve
7	Type 2
12	1Kohm RTD
24	Type 3

Code	Enclosure
PE	Plastic box for EMT Connection
PW	Plastic water resistant box
-	Electrical box

DTS-FL: Flange Mount Duct Temperature Sensor



Ordering Information:

DTS - FL - 12 - 12 - 7

Code	Description
DTS	Duct Temperature Sensor

Code	Description
FL	Flange Mount

Code	Probe Size
4	4"
8	8"
9	9"
12	12"

Code	Wire Size
6	6"
12	12"(1ft)
120	120"(10ft)

Code	Temperature Curve
6	3 Kohm RTD
7	Type 2
12	1Kohm RTD
24	Type 3

OAT: Outside Air Temperature Sensor



Installation:

- The OAT sensor can be mounted on the outside of the building using the following guidelines:
- Choose a spot on the north face which will be out of sunlight for as much of the day as possible.
 - Mount the sensor where it can be serviced, staying away from exhaust ducts. Point the probe downwards to avoid catching rain.
 - To install the sensor, drill a 3/4" (20mm) hole through the wall, and pipe the sensor to an electrical junction box on the inside of the wall. The sensor has a female 1/2" NPT threaded fitting to accept a short length of 1/2" pipe or PVC. The sensor requires two conductors, normally 18ga unshielded twisted pair.

Room Temperature Sensor

RTS:



RTS1:



RTS3:



Dimensions(mm):

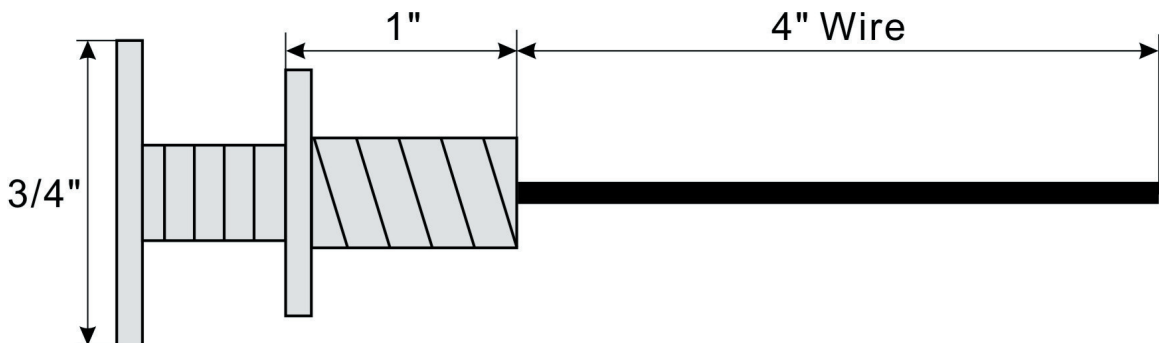
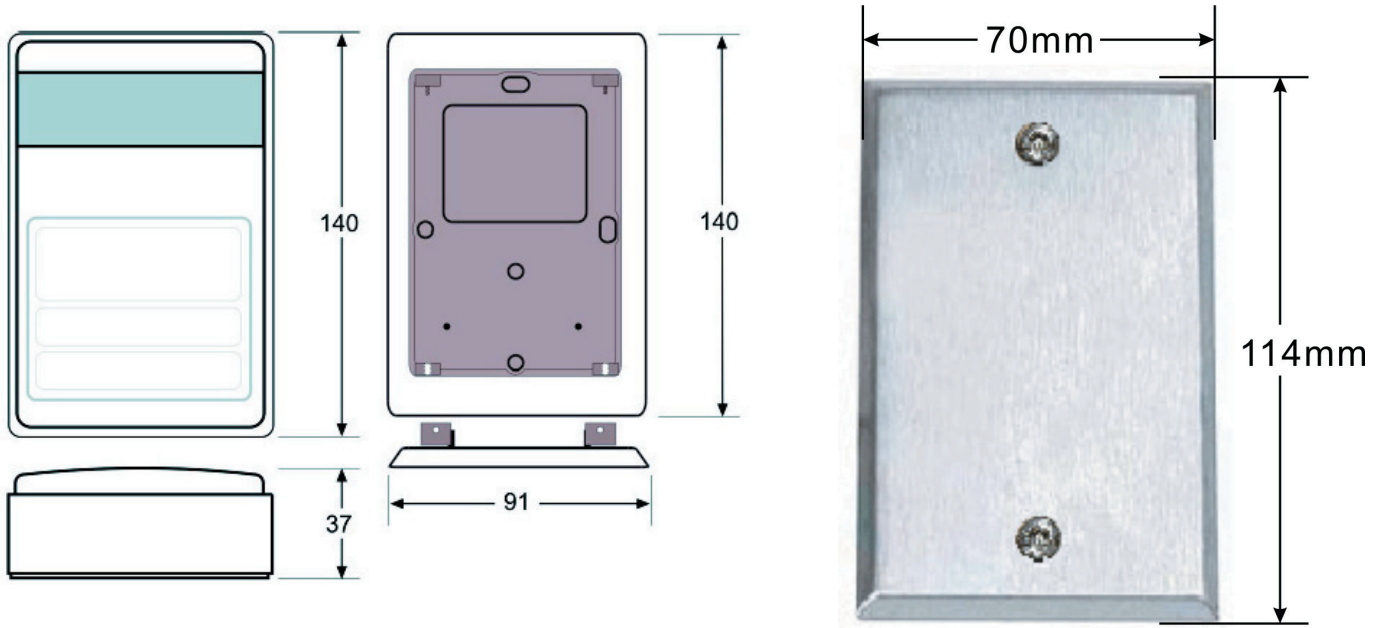

WTS Series Water Temperature Sensor

WTS:

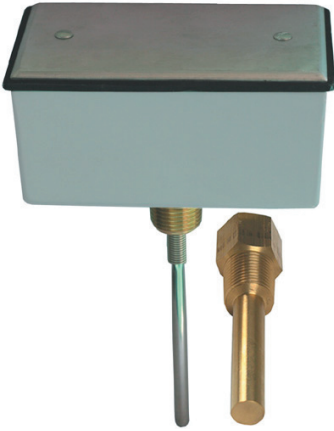

WTS-P:

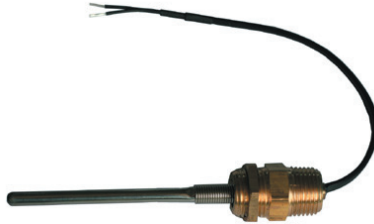

WTS5:



Installation:

Locate water temperature sensor at least a few pipe diameters downstream any heat or cooling source:

- A 1/2" NPT female pipe fitting is welded into the pipe. These fittings are usually supplied and installed by the piping trade under direction of the controls trade.
- Choose an orientation where any condensation will not collect, such as the top of a horizontal pipe section or at a 45deg angle from horizon.
- Before threading the sensor into the well, deposit some thermal paste in the bottom of the well to improve heat conduction between the metal parts.
- The sensor is wired with two conductors, normally 18ga unshielded twisted pair.

Wells

Descriptions:

These thermowells are designed for mounting temperature sensors in pipes and tanks. The thermowells are designed to reduce the stress encountered in flowing fluid installation which produces a constantly oscillating force that can eventually crack a probe unless it is mounted in one of these wells. The wells are designed to handle this stress yet provide good thermal contact with the fluid. They also provide isolation, if the sensor needs to be serviced the system can remain in operation without having to drain down the lines.

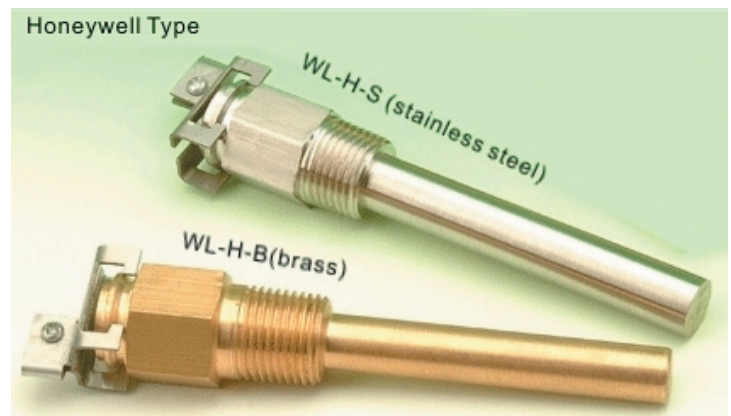

Features & Options:

- Three Lengths: 2", 4" and 8" (Fit standard Immersion Unit lengths)
- Stainless Steel (304 or 316) or Brass
- Two Part (Welded) or Machined Construction
- Other Lengths or Materials Available Upon Request
- Limited Lifetime Warranty

2 Part (Welded) Temcowell Standard Temcowells available from Temco include 304 stainless steel (machined), 316 stainless steel (machined), brass (machined), and two part (welded) stainless steel. These wells are offered in 2", 4" and 8" lengths with 1/2" NPT external and 1/2" NPSM. Other lengths and thread diameters are available upon request. The Thermowell chosen for the installation is governed mainly by the corrosion conditions the well will face. The machined stainless steel wells all come with a mirror polish to provide maximum corrosion resistance. Occasionally, the material consideration is one of strength rather than corrosion. For example, a machined stainless steel well may be required for high pressure water service where otherwise a brass or two part stainless steel well would be satisfactory from a corrosion standpoint. market require.

Well failures, in most cases, are not due to the effects of pressure or temperature on the well. The calculations necessary to provide adequate strength, under given conditions, are familiar enough to permit proper choice of wall thickness and material. The values shown in Table 1 are conservative, and intended primarily as a guide.

Wells are also safe if the resonant frequency is well below the wake frequency or if the fluid velocity is constantly fluctuating through the critical velocity point. Nevertheless, if the installation is not hampered by the use of a sufficiently stiff well.

Dimensions

